

ALTAIR[®] DUALAIR[™]

Secondary Glazed Louvre
Component System

Winner of the
2018 AWA
*'Most Innovative
Window System'*
Design Award



breezway[®]

Dualair™ System

High Performance Glazing



The Altair® Dualair™ Louvre Component System is a sophisticated secondary glazed unit that has been designed to provide superior water penetration resistance and sound performance.



Improved Performance for Commercial Designs

Breezway's new Altair Dualair Component System has been carefully designed to deliver a high performance dual glazed louvre system to the commercial market.

The system provides outstanding results for improved water penetration, allowing larger window sizes to be installed into project designs. Through the use of two louvre galleries inside the one frame, significant sound reduction can be achieved as well as excellent ventilation and shading to keep buildings cool and comfortable.

The secondary glazed Dualair System provides good thermal insulation comparable to that of high performance double glazing in thermally broken framing, thus making the system ideal for projects with high R_w or low U-value requirements.



WATER PENETRATION

Significantly improved water penetration resistance - Up to 620Pa Water Penetration Resistance at floor to ceiling window sizes.



ACOUSTIC INSULATION

Excellent sound acoustics to reduce outdoor noise - R_w ratings up to 35.



MAXIMUM VENTILATION

Maximum ventilation to keep building occupants comfortable.



THERMAL INSULATION

U-values ranging from 2.4 to 3.3 give comparable performance to double glazed windows with thermally broken frames.



AESTHETICS

Single window unit gives better aesthetics. Using aluminium or patterned blades can create a decorative effect to the building facade.



SHADING / PRIVACY

Use aluminium or patterned glass blades on outer blades to provide shading and privacy.



REDUCED INSTALLATION COSTS

Secondary glazing within a single frame results in a single installation occasion.

Product Offer

- Compatible with the Alspec® McArthur Evo™ and Alspec Hunter Evo™ Acoustic 150mm Framing Systems.
- The outer gallery must always be an Altair Powerlouvre™ Gallery, the inner gallery can be a Powerlouvre Gallery or manually operated.
- Standard heights only.
- 6mm thick, 152mm glass or aluminium blades only.
- Full range of colour and handle customising options available.
- Fully compatible with the Stronghold® System with restricted openings to satisfy Fall Prevention requirements.

Extensive Testing

A number of tests have been completed for the Dualair System with more to come in the near future.

Please visit www.breezway.com.au/dualair for up to date test results as they become available.

Head detail of two Altair® Louvre Galleries in 150mm Commercial Frame.

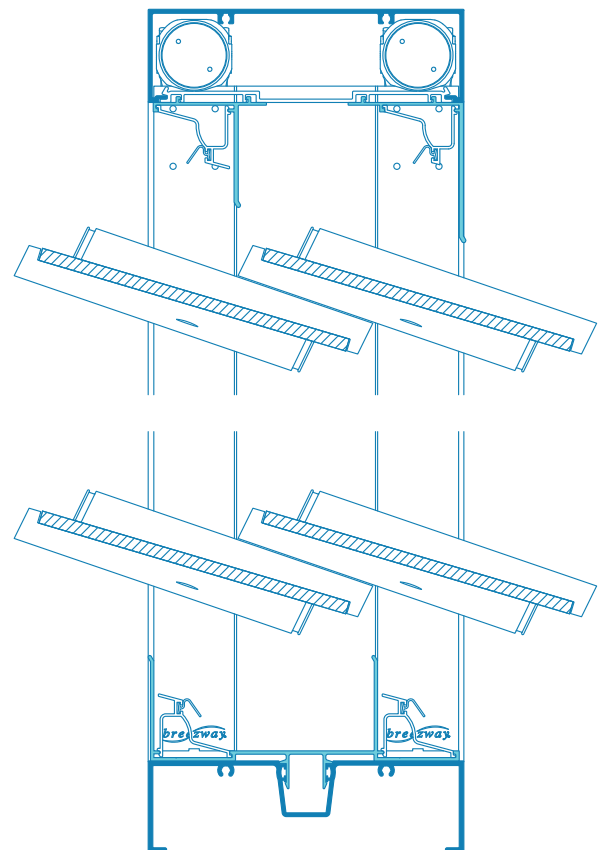

Sill detail of two Altair® Louvre Galleries in 150mm Commercial Frame.



Breezway Head Office

35 Cambridge Street
Coorparoo QLD 4151
ABN 24 081 897 823
+61 7 3847 0500
designassist@breezway.com.au
breezway.com.au

Where to View/Buy

Breezway sole manufactures however our louvres are available to view or buy through a highly qualified network of window fabricators.

Please visit our website to locate your closest supplier.

Dualair™ Window System Heights for 152mm Blade

No. of Blades	Height ¹	Height ²	Height ³
All dimensions are in millimeters (mm)			
2	418	423	328
3	558	563	468
4	698	703	608
5	838	843	748
6	978	983	888
7	1118	1123	1028
8	1258	1263	1168
9	1398	1403	1308
10	1538	1543	1448
11	1678	1683	1588
12	1818	1823	1728
13	1958	1963	1868
14	2098	2103	2008
15	2238	2243	2148
16	2378	2383	2288
17	2518	2523	2428
18	2658	2663	2568

- 1. **Head:** Alspec McArthur Evo
Sill / Transom: Alspec McArthur Evo
- 2. **Head:** Alspec McArthur Evo
Sill / Transom: Alspec Hunter Evo Acoustic
- 3. Daylight Opening Height

